

# 規格承認書

## SPECIFICATION FOR APPROVAL

客 戶:  
(CUSTOMER) \_\_\_\_\_

產 品: SWITCHING POWER SUPPLY  
(PRODUCTS) \_\_\_\_\_

型 號: BT-2400U-T  
(PART NUMBER) \_\_\_\_\_

樣 品 數 量:  
(SAMPLE Q'TY) \_\_\_\_\_

批 准 APPROVED	審 核 CHECKED	承 辦 TESTED

宏元电气设备有限公司/ ATNG POWER CO., LTD.

公 司: 东莞市塘厦镇振兴围上塘路 89 号 A 栋 3 楼

TEL: 0769-87720461 FAX: 0769-87720465

一统兴业有限公司/ ATNG POWER CO., LTD

公 司: 台北县三重市重新路 5 段 609 巷 14 號 3 楼之 9

OFFICE: 3F-9, NO. 14, LANE 609, SEC 5 CHUNG SHUN RD, SAN CHUNG CITY, TAIPEI SHIEN, R.O.C.

TEL: 886-2-2278-2506(REP) FAX: 02-2278-1792 E-mail: Service@atngpower.com.tw

# TABLE

<b>1. General Requirements.....</b>	<b>1</b>
<b>2. Input Requirements.....</b>	<b>1</b>
<b>2.1Harmonics.....</b>	<b>1</b>
<b>2.2AC Inlet Connector.....</b>	<b>1</b>
<b>2.3AC Input Voltage Specification.....</b>	<b>1</b>
<b>2.4Efficiency.....</b>	<b>1</b>
<b>2.5AC Inrush Current.....</b>	<b>1</b>
<b>3. DC Output.....</b>	<b>2</b>
<b>3.1 Voltage /Current.....</b>	<b>2</b>
<b>3.2 Dynamic Loading.....</b>	<b>2</b>
<b>3.3 DC Connectors.....</b>	<b>2</b>
<b>4. Protection Circuits.....</b>	<b>2</b>
<b>4.1 Over Voltage Protection(OVP).....</b>	<b>3</b>
<b>4.2Short Circuit Protection(SCP).....</b>	<b>3</b>
<b>4.3 Over Power Protection (OPP) .....</b>	<b>3</b>
<b>4.4 Over Temperature Protection (OTP) .....</b>	<b>3</b>
<b>5. Physical Environment.....</b>	<b>3</b>
<b>5.1Operation Conditions.....</b>	<b>3</b>
<b>Attachment 1    Drawing</b>	

## 1. General Requirements

This power supply is designed for litecoin or bitcoin miner. There are one DC outputs: +12V it will provide power to all system components.

## 2. Input Requirements

### 2.1 Harmonics

The power supply shall incorporate universal power input active power factor correction, which shall reduce line harmonics in accordance with the EN61000-3-2 and JEIDA MITI standards.

### 2.2 AC Inlet Connector

The AC input connector shall be an IEC 320 C-14 power inlet.

### 2.3 AC Input Voltage Specification

The power supply must operate within all specified limits over the following input voltage range. Harmonic distortion of up to 10% THD must not cause the power supply to go out of specified limits.

**AC Input Rating**

Parameter	Min.	Nom.	Max.	Unit
Vin (Full range)	180-200	200-240	264	Vrms
Vin Frequency	50-60			Hz
Full Load	100%	100%	100%	Watts
AC Current	12			Arms

Note: Power factor correction (PFC) >0.95 at full load.

### 2.4 Efficiency

This model has 92% or greater energy efficient at 100% utilization, for energy and money saving. (@230Vac)

### 2.5 AC Inrush Current

Maximum inrush current from power-on (with power on at any point on the AC sine) and including, but not limited to, three line cycles, shall be limited to a level below the surge rating of the input line cord, AC switch if present, bridge rectifier, fuse, and EMI filter components. Repetitive ON/OFF cycling of the AC input voltage should not damage the power supply or cause the input fuse to below.

## 3. DC Output

**3. DC Output**

**3.1 Voltage /Current**

Output Voltage	Minimum Load	Maximum Load	Load Reg.	Line Reg.	Ripple & Noise
+12.3V	0A	183A	±2%	±1%	180 mV p.p

- A. Maximum continuous total DC output power should not exceed 2200W.
- B. Ripple and noise measurements shall be made under all specified load conditions through a single pole low pass filter with 20MHz cutoff frequency. A 0.1uF ceramic disk capacitors in parallel with a 10uF tantalum are placed at the point of measurement. See Figure 1.

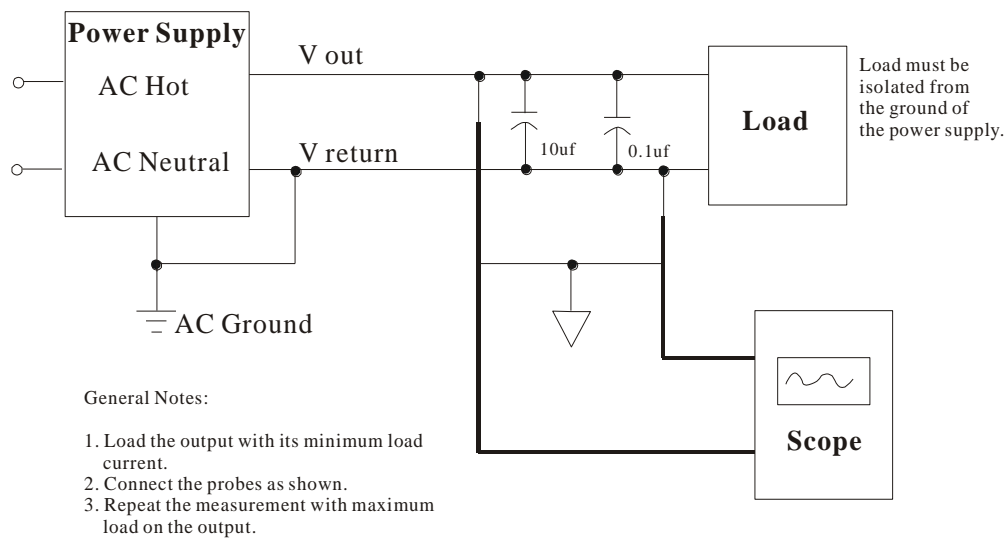

**Figure 1. Differential Noise Test Setup**

**3.2 Dynamic Loading**

The output voltages shall remain within the limits specified in section 3.1 for the step loading and within the limits specified in below Table for the capacitive loading. The load transient repetition rate shall be tested between 50 Hz and 5 kHz at duty cycles ranging from 10%-90%. The load transient repetition rate is only a test specification. The  $\Delta$  step load may occur anywhere within the MIN load to the MAX load shown in section 3.1

**Transient Load Requirements**

output	$\Delta$ Step Load Size	Load Slew Rate	Capacitived Load
+12V	25% of max load	0.5A/ $\mu$ s	1000 $\mu$ F

**3.3 DC Connectors**

**PCI-E Power Connector for miner**

Connector housing: 6-Pin WST P/N: P6-I42002K5 or equivalent

**Pin and Cable Color Assignment**

Pin	Signal	Cable Color	Pin	Signal	Cable Color
1	+12VDC	Yellow	4	COM	Black
2	+12VDC	Yellow	5	COM	Black
3	+12VDC	Yellow	6	COM	Black

**Note: Output cables may be different in designated model on the length, connector type and/or quantity.**

## 4. Protection Circuits

### 4.1 Over Voltage Protection (OVP)

The power supply over voltage protection shall be locally sensed. The power supply shall shutdown and latch off after an over voltage condition occurs. This latch shall be cleared by an AC power interruption. The below enclosed table contains over voltage limits. The values are measured at the output of the power supply's connector. The voltage shall never exceed the maximum levels when measured at the power pins of the power supply connector during any single point of fail. The voltage shall never trip any lower than the minimum levels when measured at the power pins of the power supply connector.

Output Voltage	MIN(V)	MAX(V)
+12V	13	14

### 4.2 Short Circuit Protection (SCP)

A short circuit on any DC output will cause the power to latch. The power supply will withstand a continuous short circuit to the output without damage or overseers to the unit.

### 4.3 Over Current Protection (OCP)

The power supply shall have current limit to prevent the +12V outputs from exceeding the values shown in below enclosed table.

Voltage	Over Current Limit
+12V	201A minimum, 274A maximum

### 4.4 Over Temperature Protection (OTP)

When power supply is over heated, it will shut-off the output. After temperature lower, power supply output will automatically recover.

## 5 Physical Environment

### 5.1 Operation Conditions

The power supply shall be capable of continuous operation and meet all electrical specification without need for adjustment when subjected to the following environ-mental conditions:

## BT-2400U-T SPECIFICATION

---

	<b>Temp. vs. Load Condition</b>	<b>Humidity</b>
Operation	-15~45 °C@Full Load	10%~90%RH
Storage	-20 °C~80 °C	5%~90%RH

\* No degradation of the power supply shall occur during shipping or storage at the specified condition.

APPROVED BY: \_\_\_\_\_ CHECKED BY: \_\_\_\_\_ PREPARED BY: \_\_\_\_\_

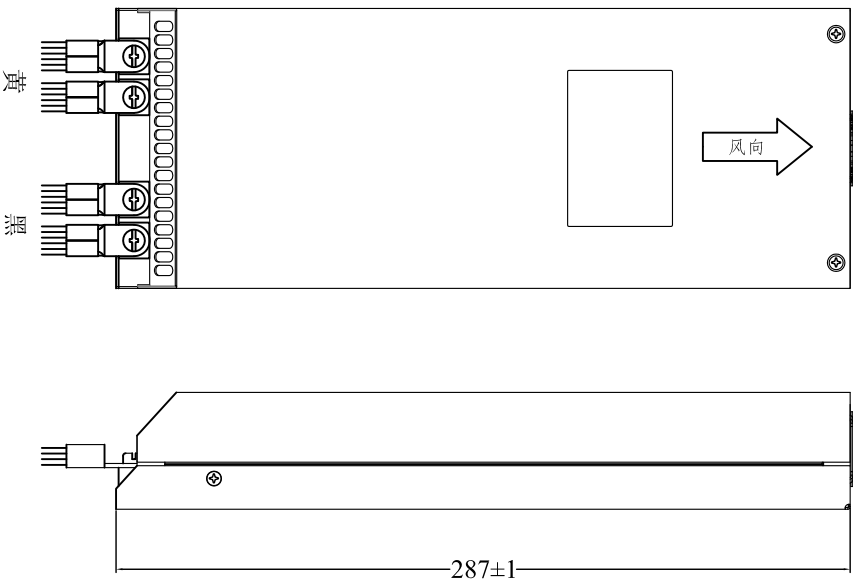
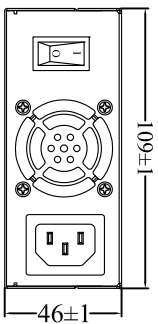

- NOTE:
1. The size of the Fan is 4cm.
  2. Actual product may slightly different from the drawings;
  3. Output cables may be different in designated model on the length,connector type and/or quantity.

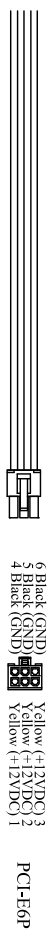
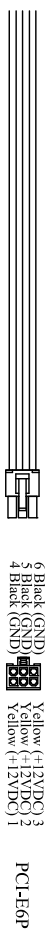
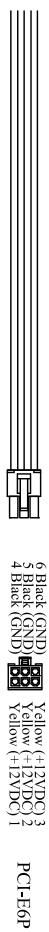
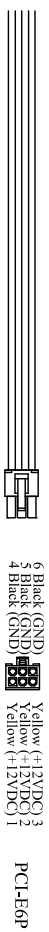
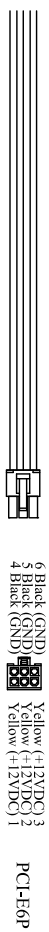
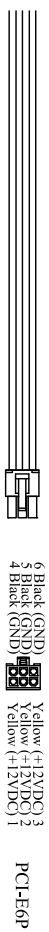
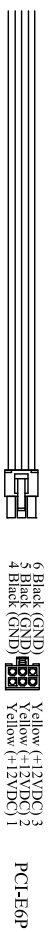

WIRE: 1007 16AWG L=300±30mm

# ATNG POWER Co.,Ltd.

DESCRIPTION	UNIT	SCALE	mm	APPROVED	CHECKED	REV: 1	MATERIAL	Preliminary
PART NO.			NON					
MODEL	BT-2400U-T	TOLERANCE						