

## 1. General Requirements

This power supply is designed for litecoin or bitcoin miner. There are one DC outputs: +12V it will provide power to all system components.

## 2. Input Requirements

### 2.1 Harmonics

The power supply shall incorporate universal power input active power factor correction, which shall reduce line harmonics in accordance with the EN61000-3-2 and JEIDA MITI standards.

### 2.2 AC Inlet Connector

The AC input connector shall be an IEC 320 C-14 power inlet.

### 2.3 AC Input Voltage Specification

The power supply must operate within all specified limits over the following input voltage range. Harmonic distortion of up to 10% THD must not cause the power supply to go out of specified limits.

**AC Input Rating**

Parameter	Min.	Nom.	Max.	Unit
Vin (Full range)	180-200	200-240	264	Vrms
Vin Frequency	50			Hz
Full Load	100%	100%	100%	Watts
AC Current	10			Arms

Note: Power factor correction (PFC) >0.95 at full load.

### 2.4 Efficiency

This model has 87% or greater energy efficient at 100% utilization, for energy and money saving.

### 2.5 AC Inrush Current

Maximum inrush current from power-on (with power on at any point on the AC sine) and including, but not limited to, three line cycles, shall be limited to a level below the surge rating of the input line cord, AC switch if present, bridge rectifier, fuse, and EMI filter components. Repetitive ON/OFF cycling of the AC input voltage should not damage the power supply or cause the input fuse to blow.

## 3. DC Output

## 3. DC Output

**3.1 Voltage /Current**

Output Voltage	Minimum Load	Maximum Load	Load Reg.	Line Reg.	Ripple & Noise
+12V	0A	133.4A	±5%	±1%	120 mV p.p

- A. Maximum continuous total DC output power should not exceed 1600W.
- B. Ripple and noise measurements shall be made under all specified load conditions through a single pole low pass filter with 20MHz cutoff frequency. A 0.1uF ceramic disk capacitors in parallel with a 10uF tantalum are placed at the point of measurement. See Figure 1.

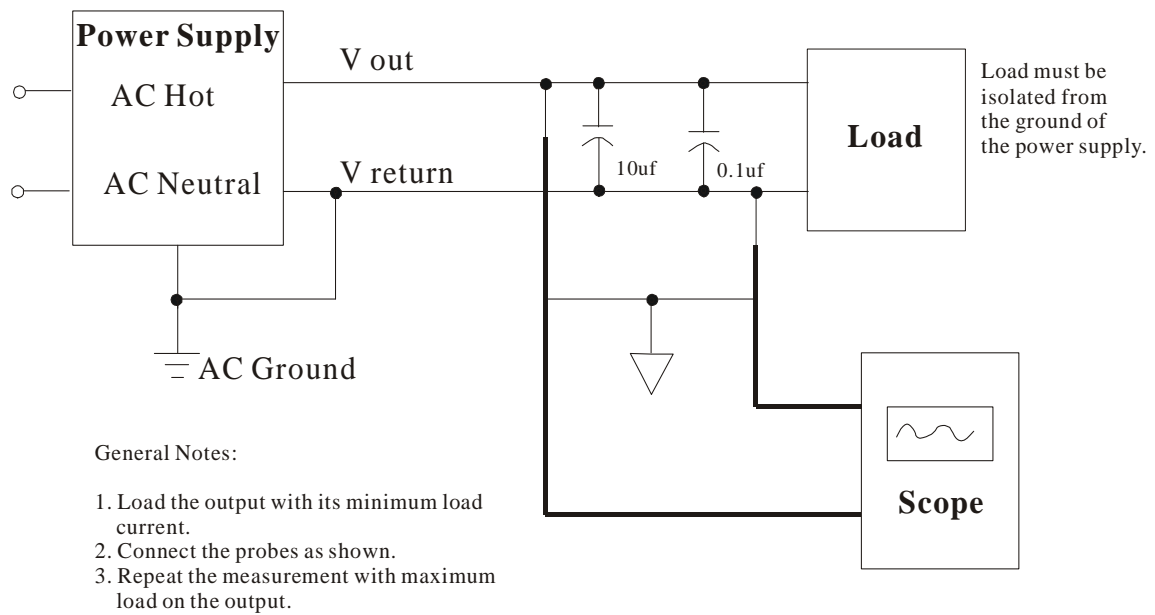

**Figure 1. Differential Noise Test Setup**

**3.2 DC Connectors**

**PCI-E Power Connector for miner**

Connector housing: 6-Pin WST P/N: P6-I42002K5 or equivalent

**Pin and Cable Color Assignment**

Pin	Signal	Cable Color	Pin	Signal	Cable Color
1	+12VDC	Yellow	4	COM	Black
2	+12VDC	Yellow	5	COM	Black
3	+12VDC	Yellow	6	COM	Black

**Note: Output cables may be different in designated model on the length, connector type and/or quantity.**

**4. Protection Circuits**

**4.1 Over Voltage Protection**

The power supply over voltage protection shall be locally sensed. The power supply shall shutdown and latch off after an over voltage condition occurs. This latch shall be cleared by an AC power interruption. The below enclosed table contains over voltage limits. The values are measured at the output of the power supply's connector. The voltage shall never exceed the maximum levels when measured at the power pins of the power supply connector during any single point of fail. The voltage shall never trip any lower than the minimum levels when measured at the power pins of the power supply connector.

Output Voltage	MIN(V)	MAX(V)
+12V	13.4	15.6

#### 4.2 Short Circuit Protection

A short circuit on any DC output will cause the power to latch with the hiccup-mode protection.

#### 4.3 Over Current Protection (OCP)

The power supply shall have current limit to prevent the +12V outputs from exceeding the values shown in below enclosed table.

Voltage	Over Current Limit
+12V	160A minimum, 213A maximum

### 5 Physical Environment

#### 5.1 Operation Conditions

The power supply shall be capable of continuous operation and meet all electrical specification without need for adjustment when subjected to the following environmental conditions:

	Temp. vs. Load Condition	Humidity
Operation	0~45°C@Full Load	10%~90%RH
Storage	-20°C~80°C	5%~90%RH

\* No degradation of the power supply shall occur during shipping or storage at the specified condition.

APPROVED BY: \_\_\_\_\_ CHECKED BY: \_\_\_\_\_ PREPARED BY: \_\_\_\_\_